



Line type heat detectors
for tunnels and industry.

SecuriHeat d-LIST and LIST

A complete model range for every application



Conveyor belts

Conveyor belts for the transport of bulk material are critical installations in the mining, distribution and storage industries as well as in manufacturing and production facilities. Despite their key importance, conveyor belts are subject to severe wear and tear. A failure would have serious consequences. Fires are a common reason for conveyor belt downtime, caused either by overheating of components or by ignition of the material being conveyed.

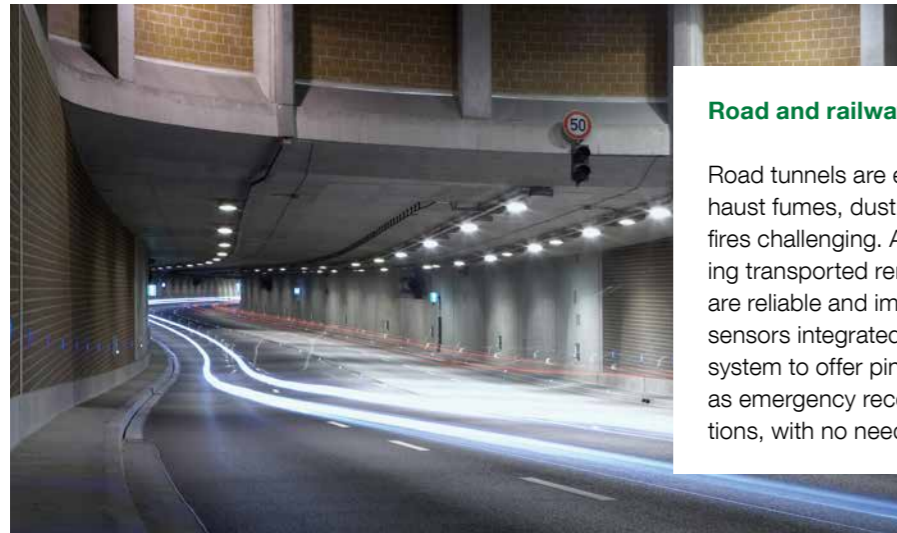

Road and railway tunnels

Road tunnels are exposed to harsh conditions consisting of exhaust fumes, dust, heat and humidity, which makes detecting fires challenging. And yet the safety of people and of assets being transported remains a top priority. Line type heat detectors are reliable and immune to these kinds of conditions. Moreover, sensors integrated in the cable enable the SecuriHeat LIST system to offer pinpoint detection. Additional installations, such as emergency recesses, are readily monitored using derivations, with no need for extra loops.



Supply tunnels

Tunnels carrying electricity, water, data, gas and district heating are key infrastructure in many major cities and conurbations. A failure in a supply tunnel would result in interruptions to these vital services. Early detection allows for rapid intervention and thus minimisation of damage. Downtime due to fire can be prevented thanks to the SecuriHeat system's precise detection capabilities.



Photovoltaic arrays

Photovoltaic arrays generating electricity are often located on the roofs of large industrial and residential buildings. Overheating of the photovoltaic panels can impair performance and even cause a fire. If this happens, rapid intervention is vital to ensure that the system and people in the building are protected. Because ambient conditions (wind, humidity, sun, etc.) preclude the use of point detectors, line type heat detectors are the ideal solution here.



Multi-storey car parks

Fires in multi-storey car parks, especially if underground, usually cause considerable damage. The intense heat means a fire can drag on for hours and endanger both life and the building's structure. The damage can be significantly reduced if the fire is detected early on by line type heat detectors, which provide reliable service in harsh ambient conditions.



Underground railway stations

Rail-based public transport in large cities tends to be underground. Because space and escape options are limited, the risk of passengers being trapped and difficult to reach in the event of a fire is high. To avoid possible panic in the event of an outbreak, early fire detection on platforms and in tunnels is essential. This, together with contingency planning, are key to safe evacuation, prevention of fatalities, damage minimisation and rapid restoration of services.

SecuriHeat d-LIST heat detector

Highly flexible protection, because every object is different

The SecuriHeat d-LIST line type heat detector with the SEC 15 sensor cable is ideal for monitoring small areas. Two sensor cables, each up to 350 metres in length, can be connected to an SCU 835 sensor control unit and put into operation at the touch of a button, with no need for additional technical equipment or previous knowledge. Featuring up to two times 100 sensors, the system can be integrated into a wide range of fire detection and alarm systems, including mobile applications (vehicles).

Multiple SCU 835s can be networked for monitoring larger areas. The d-LIST system can also be supplemented with individual temperature sensors in metal housings for monitoring critical infrastructure such as conveyor belt or escalator drives. The sensor control unit displays the current operating state for at-a-glance reassurance.

The SCU 835 includes a Modbus RTU and TCP interface for access by other systems, and the XLM35 module provides a direct connection to the SecuriFire fire alarm control panel.



SecuriHeat SCU 835 for small objects

- Cable length up to 2 x 350 m
- Up to 5 derivation options
- VDS approval according to EN 54-22:2020-07

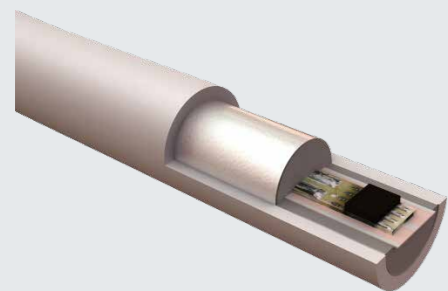

SEC 15 cable

- Sensor spacing 1 to 10 m
- Diameter 15 mm
- Operating temperature -40°C to +85°C
- Halogen-free
- Aluminium sheath protects against environmental influences

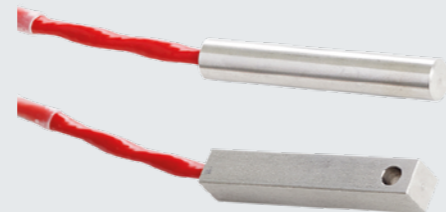

Single sensor

- Round or square sensors available
- Material: stainless steel
- For use with the CBO 15-ESD box only

SecuriHeat LIST heat detector

Starts where everyone else stops

The SecuriHeat LIST line type heat detector is the ideal fire marshal for tunnels and large-scale industrial applications. It consists of the SEC 20 sensor cable and the LIST controller. The system is capable of monitoring distances up to 3500 metres or up to 350 sensors. The LIST controller can accommodate up to two sensor cables (one sensor cable with various derivations as a stub line, two sensor cables with a LIST controller as a loop, two sensor cables with two LIST controllers as a redundant loop). Detection and alarm threshold values can be configured for up to 254 different alarm sections. The system measures the temperature of the sensors every ten seconds and compares it with the programmed threshold value.

The LIST controller is highly convenient both before and during operation. Its configuration and operating data can be imported from a USB stick. The automatically recorded log files can also be exported via USB stick in the event of an incident. Operation is intuitive thanks to the plain-text display in multiple languages on the controller display, as well as the navigation and function keys.



SecuriHeat LIST controller for large applications

- Cable length up to 3500 m
- Redundant operation
- VDS approval according to EN 54-22:2020-07

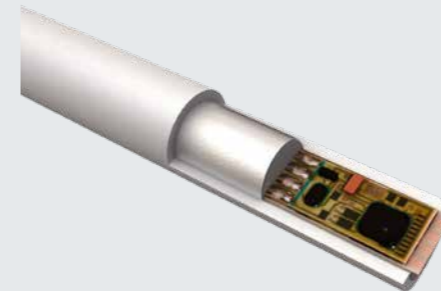

SEC 20 cable

- Sensor spacing 1 to 10 m
- Diameter 18 mm
- Operating temperature -40°C to +85°C
- Halogen-free
- Aluminium sheath protects against environmental influences

Operation and configuration

d-LIST system configuration

The SCU 835 can be operated and configured using the d-LISTconfig graphical user interface. Connection is possible via RS485, RS232, USB as well as the Ethernet interface.

All the data present in the devices is visualised and can be compiled in a report.

- Temperature and data display, export reports
- Device and sensor cable status display
- Up to 999 event memory entries in the loop memory
- Temperature changes of up to three sensors displayed continuously in a graphic
- Input and output programming
- Interface state display
- Dongle-based operation with four access levels
- German/English as operating languages can be changed in the software

LIST system configuration

The LIST controller has a built-in web interface that can be accessed on a PC via the Ethernet interface.

The web interface is the door to the LIST system and is used for commissioning, maintenance and troubleshooting.

- Eight-language web interface, differentiated by four access levels
- Summary display of device settings and software version
- Next maintenance date display
- Device and sensor cable status display
- Relay and communication state display
- Fault state display
- Message list and maintenance file export
- Fire section on/off switching

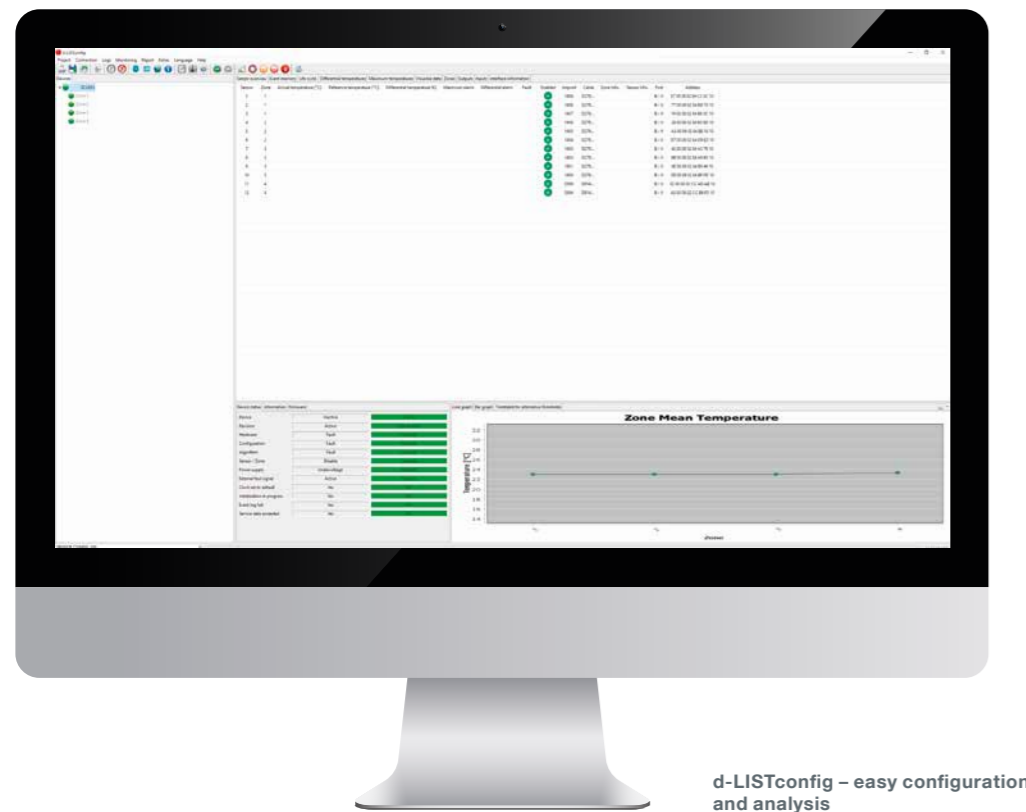

Alarm management, process monitoring and temperature monitoring

Sensor cable applications

Alarm transmission via fire alarm is the traditional method if a sensor cable system detects a fire. The alarm is forwarded to the emergency services via the SecuriFire alarm control panel so that an intervention can be made as quickly as possible.

However, d-LIST and LIST sensor cable systems can also provide an early warning, enabling interventions to be made even before the fire alarm is triggered by fire. This has the major advantage of preventing system downtimes. Precision monitoring by the cables sensors enables large numbers of different areas to be monitored.

Examples:

- Conveyor belts (monitoring rollers for overheating)
- Tunnels (monitoring of fire sections)
- Parking (monitoring of overheating vehicles)

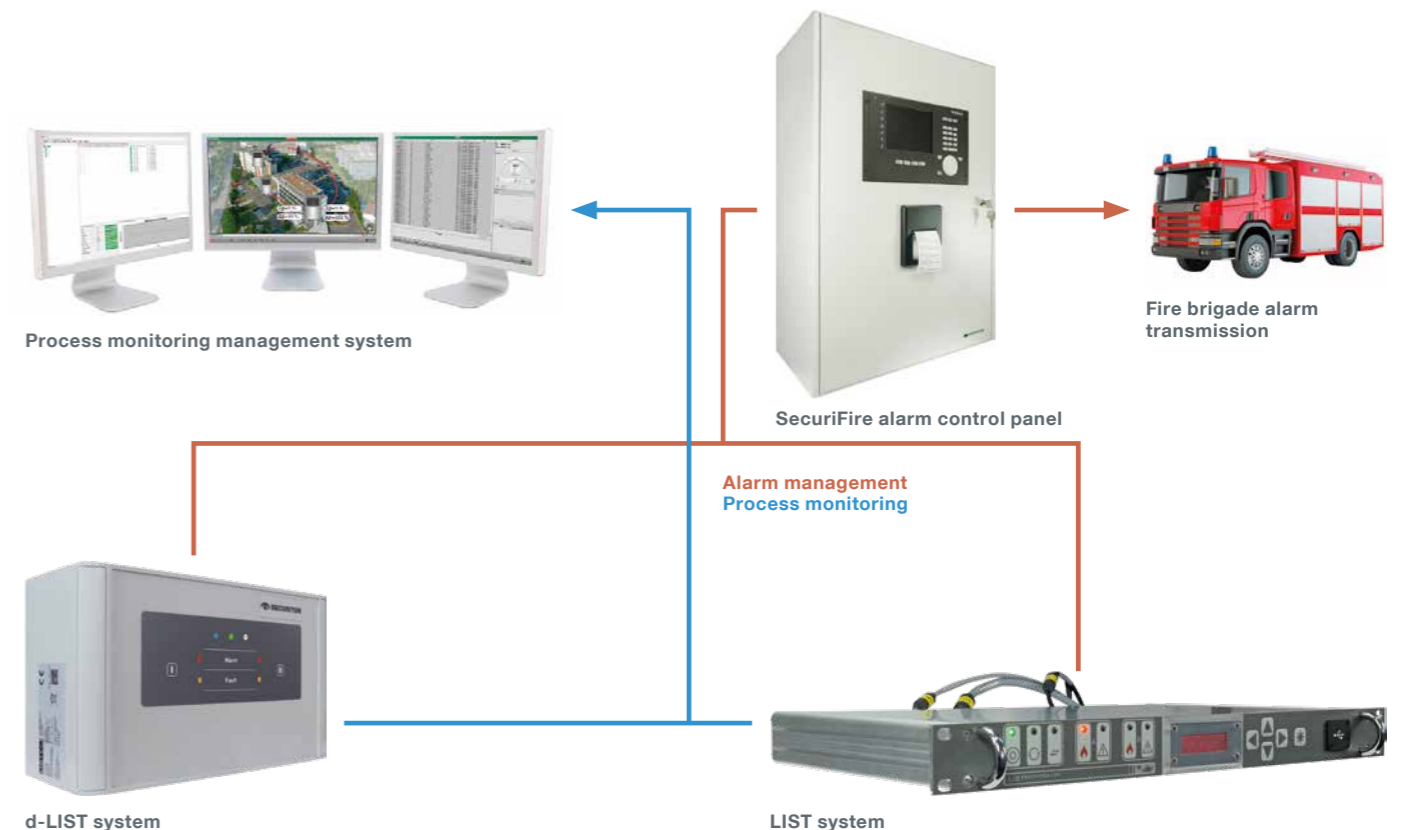

Fact sheet SecuriHeat d-LIST and LIST

d-LIST:

Cable length

700 m

The SecuriHeat d-LIST line type heat detector with cable lengths of up to 700 m is the ideal fire marshal for industrial applications. It consists of the SEC 15 sensor cable and the SCU 835 sensor control unit, which can evaluate 350 m of cable per channel.

Detection sensors with spatial resolution

200 sensors 350 sensors

For pinpoint temperature measurement, the d-LIST system enables up to 100 sensors per channel to be linked to the SCU 835.

LIST:

3500 m

The SecuriHeat LIST line type heat detector with cable lengths of up to 3500 m is the ideal fire marshal for long distances, e.g. tunnels and industrial conveyor belts. It consists of the SEC 20 sensor cable and the LIST controller.

The LIST system enables up to 350 sensors to be connected to the LIST controller.

Redundancy

Two LIST controllers can be operated as a redundant loop with two SEC 20 sensor cables.

Robust and accurate

The sensor cables are equipped with a sealed aluminium sheath as shielding against environmental influences. The cable sheath is also halogen-free and flame-retardant in accordance with DIN EN 60332. The measuring points capture the temperature with a resolution of 0.1 °C. The sensor cables do not have to be recalibrated.

Cable derivations

Thanks to derivations, which are very easy to accomplish, the sensor cables can be tailored to the given conditions of the installation, such as emergency bays in tunnels.

Maintenance-free sensor cables

The sensor cables require no maintenance since there are no wearing parts.

Networking

Various interfaces (serial and LAN) are available in the controller for exporting the status and measurement data to management systems. The total length of sensor cable can be increased by networking several d-LIST or LIST systems.

Simple to repair

Sensor cables can be easily repaired, e.g. in the event of a cable defect.

From conveyor belt to tunnel – the right accessory for every application

d-LIST accessories

Additional material:



MB SCU 835
Replacement circuit board

REL 835
Relay circuit board with 16 relay contacts

Sensors and cables:



SEC 15 sensor cable ESD-A5 individual sensors CC 15 connection cable

Connection boxes:



CBO 15-SEC
Connection box for SEC 15 sensor cable, individual ESD sensors and CC 15 connection cable

CBO 15-ESD

Sensors and cables:



CLIC 15 MDC MDJ
Stainless steel bracket for sensor cable mounting

LIST accessories

Additional material:



SEC 20 sensor cable RELMOD
Relay module with 16 relays and 8 inputs CC 20 cable
Connection cable for SEC 20 sensor cable



CSM 200
SEC 20 sensor cable simulator LCT 20
SEC 20 sensor cable tester

Connection boxes:



CBO 20/0 CBO 20/1 CBO 20/3
For connecting SEC 20 sensor cable and CC 20 connection cable

Installation material:



CLIC 17
For SEC 20 cable installation MDJ
Stainless steel bracket for sensor cable mounting

In use around the world with globally applicable certifications

Global product tests and certifications mean the SecuriHeat d-LIST and LIST enjoy universal market access and can be deployed worldwide.

SecuriHeat d-LIST and LIST speak multiple languages: globally applicable standards such as NFPA 72, VDE 0833-2, TS 54-14, BS 5839-1, etc. can be met in all confidence when planning a system.

📍 Securiton has a global presence. Our headquarters are located in Switzerland, and we have subsidiaries or local staff operating in Mexico, Brazil, Spain, Russia, India, Malaysia and China.



SecuriHeat d-LIST heat detector at a glance

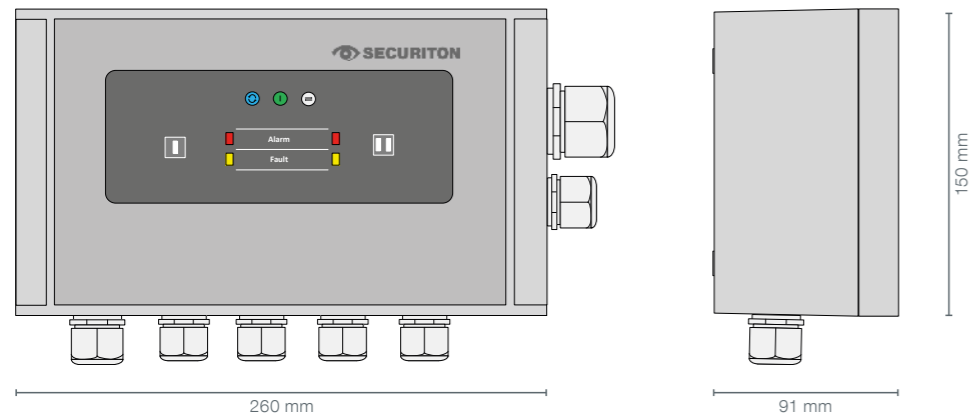

SCU 835 cable terminal processor

Technical data	
Supply voltage	10.5 to 30 VDC
Power consumption	4.4 W (normal operation)
Relays per channel	1 x alarm/ 1 x fault (fail-safe)
Optional REL 535 relay circuit board	16 x freely programmable
Relay contact load	30 VDC/30 W 1A max.
Inputs	4 x opto-isolated inputs, 5..30 VDC/ 1 x reset input, 5..30 VDC
Weight	1.95 kg with REL 835 2.1 kg
Housing material	Aluminium
Operating temperature	-25 to +70 °C
Protection type	IP 65
Interfaces	RS 232: parameterisation RS 485: parameterisation, network, connection to third-party systems USB: parameterisation, firmware update Ethernet: parameterisation, connection to third-party systems
VdS approval compliant with EN 54-22:2020-07	G221004

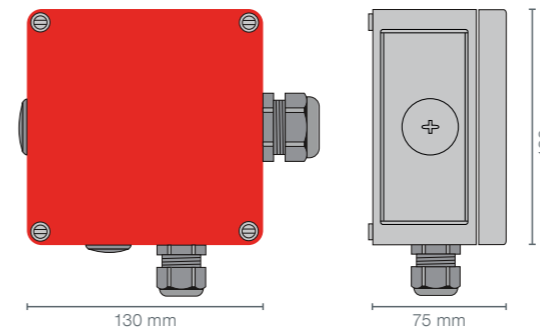

Connection box CBO 15-SEC CBO 15-ESD

Technical data		
Connection	1 or 2 SEC 15 sensor cables	8 ESD-A5 individual sensors or 1 SEC 15 sensor cable and 4 individual ESD-A5 sensors
Housing material	Glass fibre-reinforced polycarbonate	
Operating temperature (continuous)	-35 °C to +70 °C (briefly +80 °C)	-35 °C to +60 °C (briefly +80 °C)
Protection type	IP 66	IP 66

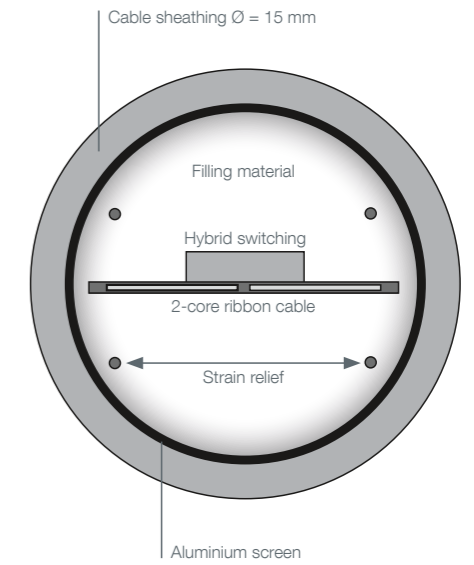

SEC 15 sensor cable

Technical data	
Standard sensor interval	1 m, 2 m, 3 m, 4 m, 5 m (others possible in the 0.25 to 10 m range)
Maximum cable length	2 x 350 m (incl. CC 15 connection cable)
Maximum number of sensors	2 x 100
Measurement range	-40 °C to +120 °C
Operating temperature (continuous)	-40 °C to +85 °C
Operating temperature (brief)	+120 °C
Resolution	0.1 °C
Cable sheathing material	Halogen-free, flame-retardant (in accordance with EN 60332-1-2, EN 60332-2-2, IEC 60754-1)
Diameter	approx. 15 mm
Weight per metre	0.35 kg/m
Colour	Grey
Min. bending radius	0.25 m
Laying temperature	> +10 °C
VdS approval compliant with EN 54-22:2020-07	G221004

SecuriHeat LIST heat detector at a glance

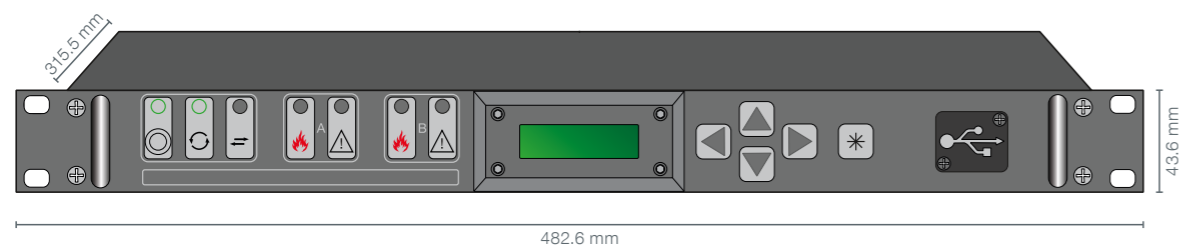

LIST controller LCON evaluation unit

Technical data	
Supply voltage	9.5-36 VDC
Power consumption	Max. 5 W (normal operation)
Relay	1 × group alarm, 1 × pre-signal, 1 × frost alarm, 1 × group fault
Relay contact load	48 VDC / 32 VAC / 250 mA max.
Dimensions	482.6 × 43.6 × 315.5 mm (W × H × D, corresponds to a 19" 1U space, installation depth with connected connecting cables approx. 400 mm)
Weight	2.6 kg
Housing material	Aluminium
Operating temperature (continuous)	-5 °C to +70 °C (-25 °C with limited readability of the LCD display)
Reset input	5-36 VDC, galvanically isolated
Interfaces	COM1: RS-485 for LIST network, COM2: RS-232 LAN: Ethernet 100 Mb/s for LIST network and maintenance USB: storage of maintenance, event and configuration data
Protocols	Modbus RTU via COM2, Modbus TCP via LAN, IEC 60870-5-104 via LAN
Indicators	LEDs for operation, alarm, fault, measurement cycle and data transmission; LC display for messages and menu-driven operation
VdS approval compliant with EN 54-22:2020-07	G213072

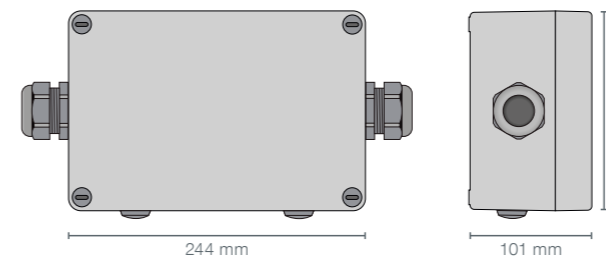

Connection box CBO 20/0 CBO 20/1 CBO 20/3

Technical data			
Connection	2 SEC 20 sensor cables	1 CC 20 cable 1 SEC 20 sensor cable	3 SEC 20 sensor cables (derivation)
Housing material	Glass fibre-reinforced polycarbonate		
Operating temperature (continuous)	-30 °C to +90 °C	-30 °C to +90 °C	-30 °C to +90 °C
Protection type	IP 66	IP 66	IP 66

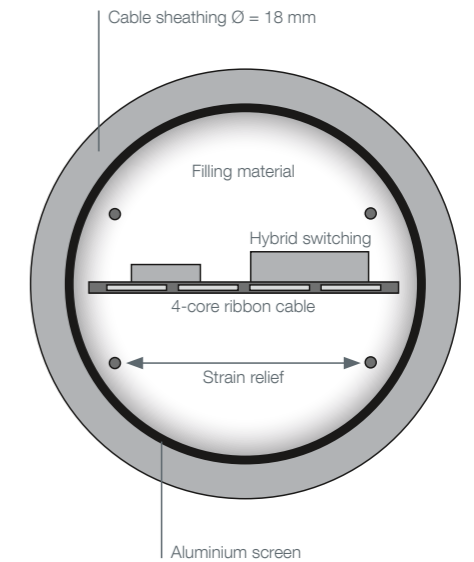

SEC 20 sensor cable

Technical data	
Standard sensor interval	2 m, 4 m, 5 m, 8 m, 10 m (others possible in the 0.5 to 10 m range)
Maximum cable length	3500 m (incl. CC 20 connection cable)
Maximum number of sensors	350 (VdS approved 320)
Measurement range	-40 °C to +200 °C
Operating temperature (continuous)	-40 °C to +85 °C
Operating temperature (brief)	+200 °C
Resolution	0.1 °C
Cable sheathing material	Halogen-free, flame-retardant (in accordance with EN 60332-1-2, EN 60332-2-2 and IEC 60754-1)
Diameter	18 mm
Weight per metre	0.45 kg/m
Colour	Grey
Min. bending radius	0.30 m
Laying temperature	> +10 °C
VdS approval compliant with EN 54-22:2020-07	G213072



Securiton AG

Alarm and Security Systems
Alpenstrasse 20, 3052 Zollikofen
www.securiton.com, info@securiton.com

A company of the Swiss Securitas Group
